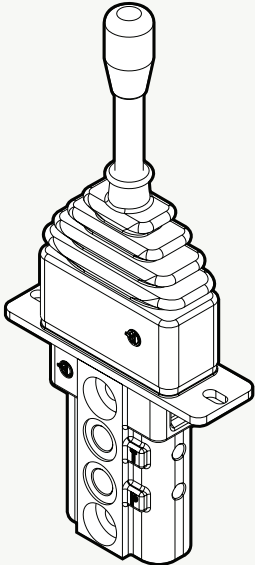
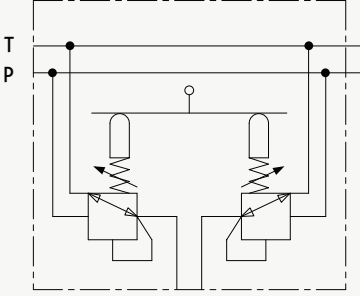
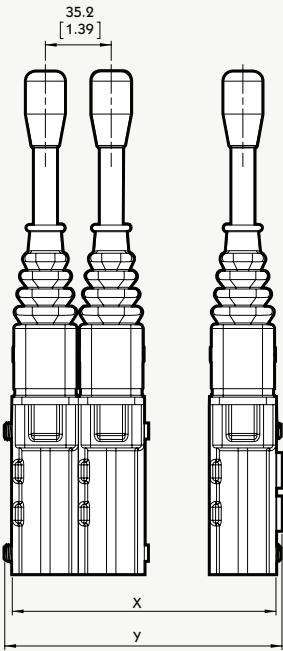
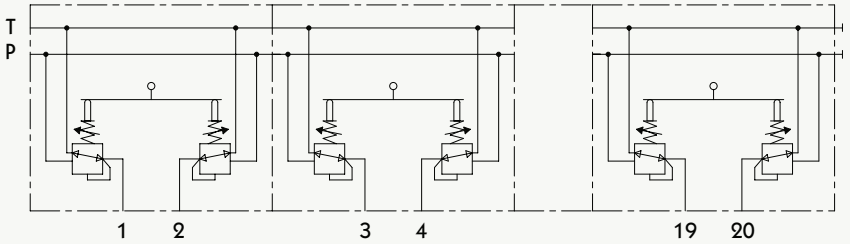

Hydraulic Pilot Linear Operation Type

液壓引導式手柄(單軸)

Type JHP-1	Code
	<p>Hydraulic Scheme:</p>  <p>HYDRAULIC PILOT CONTROLLER OPTIONS: 8, 9-1, FD, LES AVAILABLE SECTIONS FROM 1 TO 10 液壓引導控制器(單軸)</p>

Type JHP-1		Code																																																							
	<p>Hydraulic circuit:</p> 	<p>Standard threads:</p> <table border="1"> <thead> <tr> <th rowspan="2">TYPE</th> <th colspan="2">X</th> <th colspan="2">Y</th> </tr> <tr> <th>mm</th> <th>in</th> <th>mm</th> <th>in</th> </tr> </thead> <tbody> <tr> <td>JHP1/2</td> <td>70.4</td> <td>2.77</td> <td>74.1</td> <td>2.92</td> </tr> <tr> <td>JHP1/3</td> <td>105.6</td> <td>4.16</td> <td>109.3</td> <td>4.30</td> </tr> <tr> <td>JHP1/4</td> <td>140.8</td> <td>5.54</td> <td>144.5</td> <td>5.69</td> </tr> <tr> <td>JHP1/5</td> <td>176</td> <td>6.93</td> <td>179.7</td> <td>7.07</td> </tr> <tr> <td>JHP1/6</td> <td>211.2</td> <td>8.31</td> <td>214.9</td> <td>8.46</td> </tr> <tr> <td>JHP1/7</td> <td>246.4</td> <td>9.70</td> <td>250.1</td> <td>9.85</td> </tr> <tr> <td>JHP1/8</td> <td>281.6</td> <td>11.09</td> <td>285.3</td> <td>12.62</td> </tr> <tr> <td>JHP1/9</td> <td>316.8</td> <td>12.47</td> <td>320.5</td> <td>12.62</td> </tr> <tr> <td>JHP1/10</td> <td>352</td> <td>13.86</td> <td>355.7</td> <td>14.00</td> </tr> </tbody> </table>		TYPE	X		Y		mm	in	mm	in	JHP1/2	70.4	2.77	74.1	2.92	JHP1/3	105.6	4.16	109.3	4.30	JHP1/4	140.8	5.54	144.5	5.69	JHP1/5	176	6.93	179.7	7.07	JHP1/6	211.2	8.31	214.9	8.46	JHP1/7	246.4	9.70	250.1	9.85	JHP1/8	281.6	11.09	285.3	12.62	JHP1/9	316.8	12.47	320.5	12.62	JHP1/10	352	13.86	355.7	14.00
TYPE	X		Y																																																						
	mm	in	mm	in																																																					
JHP1/2	70.4	2.77	74.1	2.92																																																					
JHP1/3	105.6	4.16	109.3	4.30																																																					
JHP1/4	140.8	5.54	144.5	5.69																																																					
JHP1/5	176	6.93	179.7	7.07																																																					
JHP1/6	211.2	8.31	214.9	8.46																																																					
JHP1/7	246.4	9.70	250.1	9.85																																																					
JHP1/8	281.6	11.09	285.3	12.62																																																					
JHP1/9	316.8	12.47	320.5	12.62																																																					
JHP1/10	352	13.86	355.7	14.00																																																					

Hydraulic Pilot Linear Operation Type

液壓引導式手柄(單軸)

Type JHP-1

Pressure control curve 壓力控制曲線

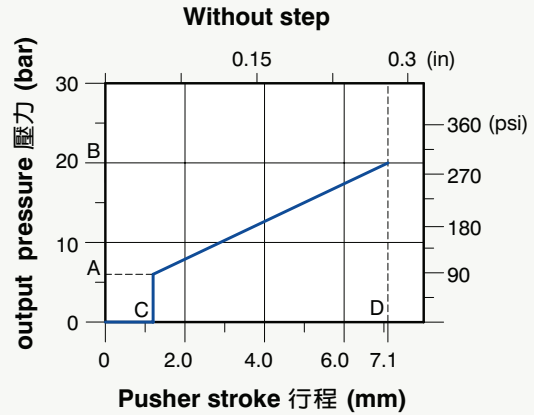
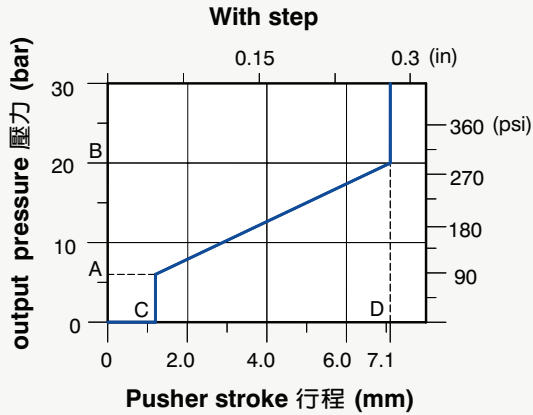

TYPE 型號	Pressure 壓力				Stroke 行程			
	A		B		C		D	
	bar	psi	bar	psi	mm	in	mm	in
01	5	72.5	19	275.5	1	0.04	7.1	0.28
02	6	87	25	362.5	1	0.04	7.1	0.28
03	8	116	42	609	0.7	0.028	7.1	0.28
04	1	14.5	9	130.5	1	0.04	7.1	0.28
05	2	29	20.5	297.3	1	0.04	7.1	0.28

Return spring type 彈簧復歸選項	
A	da 17.4N a 25.9N
B	da 22.2N a 33N
C	da 25.6N a 65.3N
D	da 78.6N a 188.1N
E	da 109.4N a 219N

Type JHP-1

Control options 控制選項

Type: 8

SPRING RETURN IN CENTER POSITION.
彈簧覆位

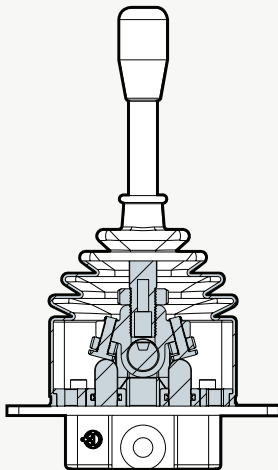

Type: FD

FRICTION DETENT, STOP IN ANY POSITION AND
NEUTRAL SENSING.
摩擦定位

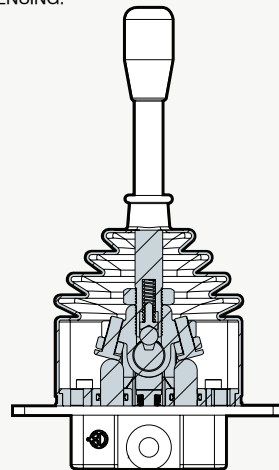

Hydraulic Pilot Linear Operation Type

液壓引導式手柄(單軸)

Type JHP-1

Type: 9-1

DETENT IN POSITION 1 AND 2, SPRING CENTERED TO NEUTRAL POSITION.

定位 1 & 2，帶彈簧復位

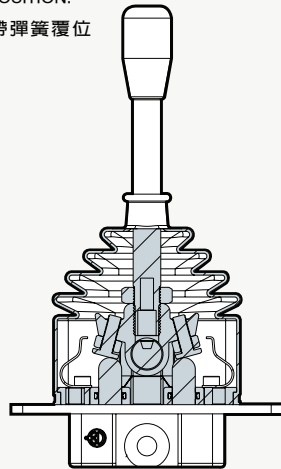

Type: LES

SAFETY LEVER, DETENT IN NEUTRAL POSITION.

安全手柄

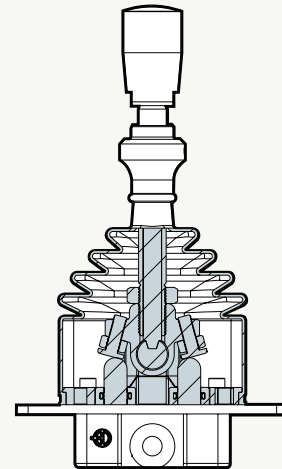

EXAMPLE-Order Code:

JHP-1 / 1S - G2 / 8 - A 01 A

1 2 3 4 5 6 7

- 1 Valve type 型號
- 2 No. of section 聯數
- 3 Thread type 螺紋規格
- 4 Control options 控制選項
- 5 Pressure control curve A or B 壓力控制選項
- 6 Pressure range 01~05 壓力選項
(see page 54 / 請參考P 54)
- 7 Spring return type A~E 彈簧復歸選項
(see page 54 / 請參考P 54)

Flow 流量	5~20 L/min	1.3~5.3 US gpm
Feeding pressure 起始壓力範圍	30~100 bar	435~1450 psi
MAX. backpressure 最大背壓	3 bar	4.35 psi
Internal leakage at 30 bar/435 psi 於 30 bar 的內洩量	10 ~ 18 cm ³ /min	0.61~1.1 in ³ /min
Fluid 流體設定	mineral oil 原油	
Fluid temperature 流體溫度	-10 ~ 80°C	-14 ~ 176°F
Ambient temperature 環境溫度	-40 ~ 60°C	-40 ~ 140°F

Standard threads

PORTS	BSP	UN-UNF	METRIC
Inlet P	G 1/4	7/16 - 20 (SAE 4)	M12 x 1.5
A and B ports	G 1/4	7/16 - 20 (SAE 4)	M12 x 1.5
Outlet T and power beyond C	G 1/4	7/16 - 20 (SAE 4)	M12 x 1.5

JHP-1/1S-G2/8-A01A/

1	2	3	4	5	6	7					
section	Threads code		Functions option	Step option 片式選項	Pressure option	Spring option					
1	2	3	4	5	6	7					
		牙規格選項	控制方式選項	曲線選項	壓力選項	彈簧復歸選項					
JHP-1	1S	G2	G-1/4	8	spring retrun	A	With step	01	5 bar - 19 bar	A	da 17.4N a 25.9N
	2S	E4	7/16-20UNF(SAE4)	9-1	detent	B	Without step	02	6 bar - 25 bar	B	da 22.2N a 33N
	3S	M12x1.5	M12x1.5	9-2		C	Piecewise with Step	03	8 bar - 42 bar	C	da 25.6N a 65.3N
	4S			9-3		D	Piecewise without Step	04	1 bar - 9 bar	D	da 78.6N a 188.1N
	5S			FD		friction detent			05	2 bar - 20.5 bar	E
	6S			LES	safety						
	7S										
	8S			9-1+FD							
	9S			9-2+FD							
	10S			9-3+FD							
				9-1+LES							
				9-2+LES							
				9-3+LES							
				FD+LES							
				FD+9-1							
				FD+9-2							
				FD+9-3							
				FD+LES+9-1							
				FD+LES+9-2							
				FD+LES+9-3							

Without step

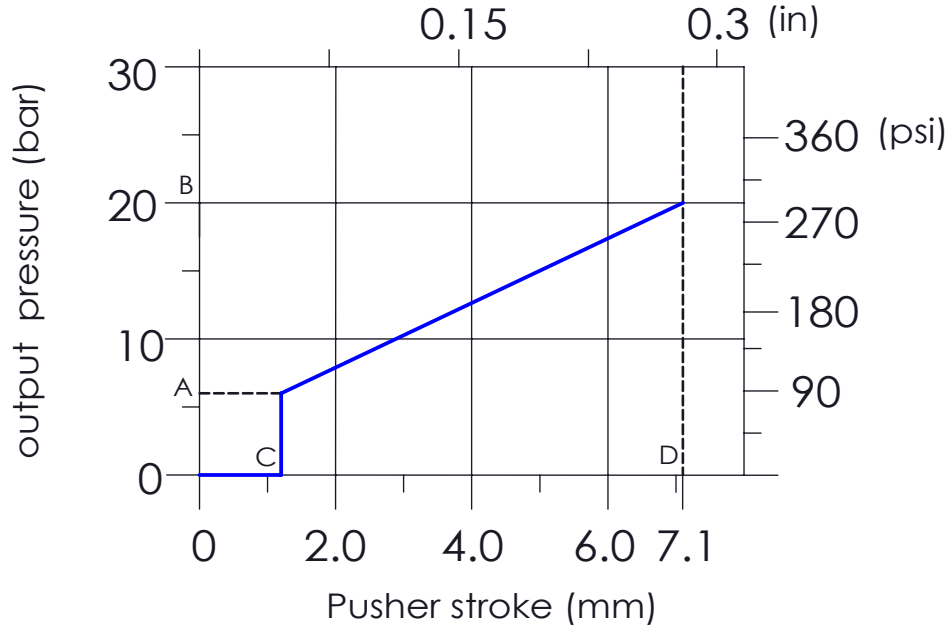

With step

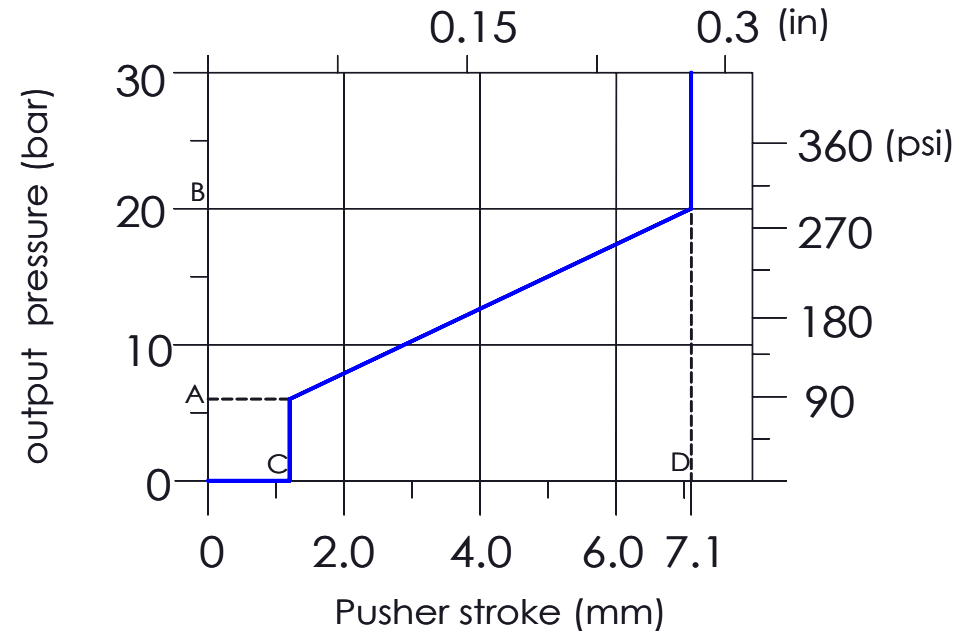

Type	Pressure				Stroke			
	A		B		C		D	
	bar	psi	bar	psi	mm	in	mm	in
01	5	72.5	19	275.5	1	0.04	7.1	0.28
02	6	87	25	362.5	1	0.04	7.1	0.28
03	8	116	42	609	0.7	0.028	7.1	0.28
04	1	14.5	9	130.5	1	0.04	7.1	0.28
05	2	29	20.5	297.3	1	0.04	7.1	0.28

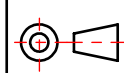
Code									
	Designer	蔡宗原	Date	2013/02/20	Valve type				
	Drawer	蔡宗原	Date	2014/02/07	Description	JHP			
	油力油壓工業股份有限公司 YOULI HYDRAULIC INDUSTRIAL CO., LTD.						Unit	mm	
							Scale	1:5	

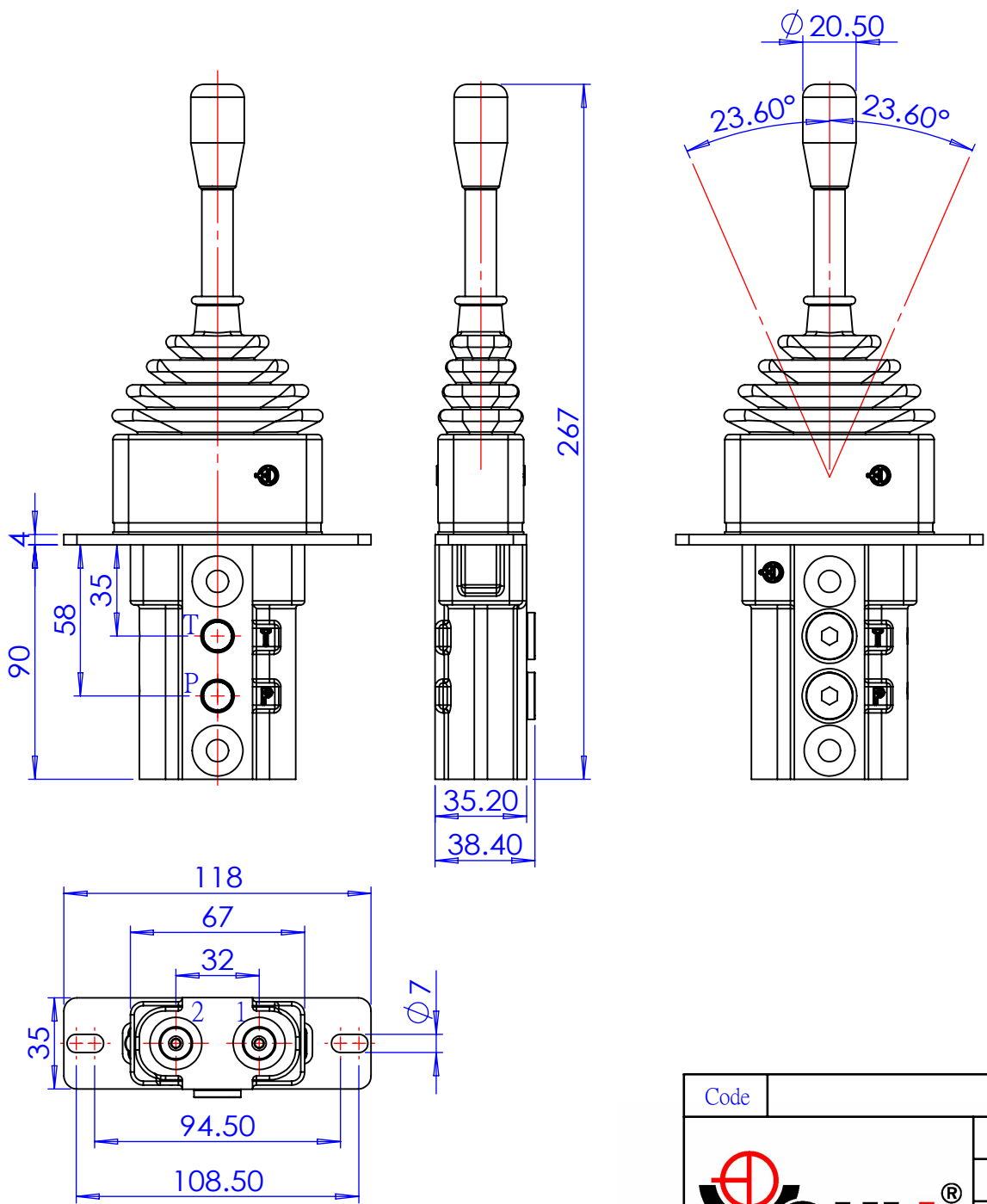

Standard threads

PORTS	BSP	UN-UNF	METRIC
Inlet P	G 1/4	7/16 - 20 (SAE 4)	M12x1.5
A and B ports	G 1/4	7/16 - 20 (SAE 4)	M12x1.5
Outlet T and power beyond C	G 1/4	7/16 - 20 (SAE 4)	M12x1.5

Flow	5~20 L/min	1.3~5.3 US gpm
Feeding pressure	30~100 bar	435~1450 psi
MAX. backpressure	3 bar	4.35 psi
Internal leakage at 30 bar/435 psi	10 ~ 18 cm ³ /min	0.61~1.1 in ³ /min
Fluid	mineral oil	
Fluid temperature	-10 ~ 80°C	-14 ~ 176°F
Ambient temperature	-40 ~ 60°C	-40 ~ 140°F

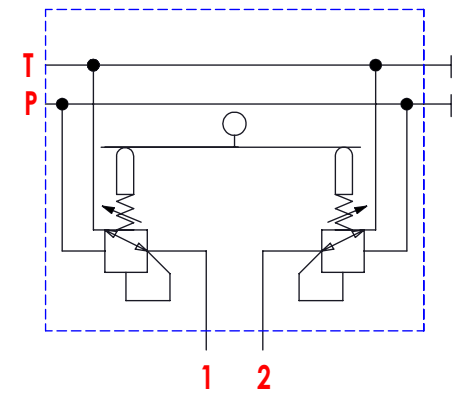

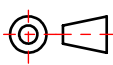
Code							
	Designer	蔡宗原	Date	2013/02/20	Valve type	JHP1	
	Drawer	蔡宗原	Date	2013/09/13	Description	1S-8	
油力油壓工業股份有限公司 YOULI HYDRAULIC INDUSTRIAL CO., LTD.						Unit	mm
						Scale	1:2.5

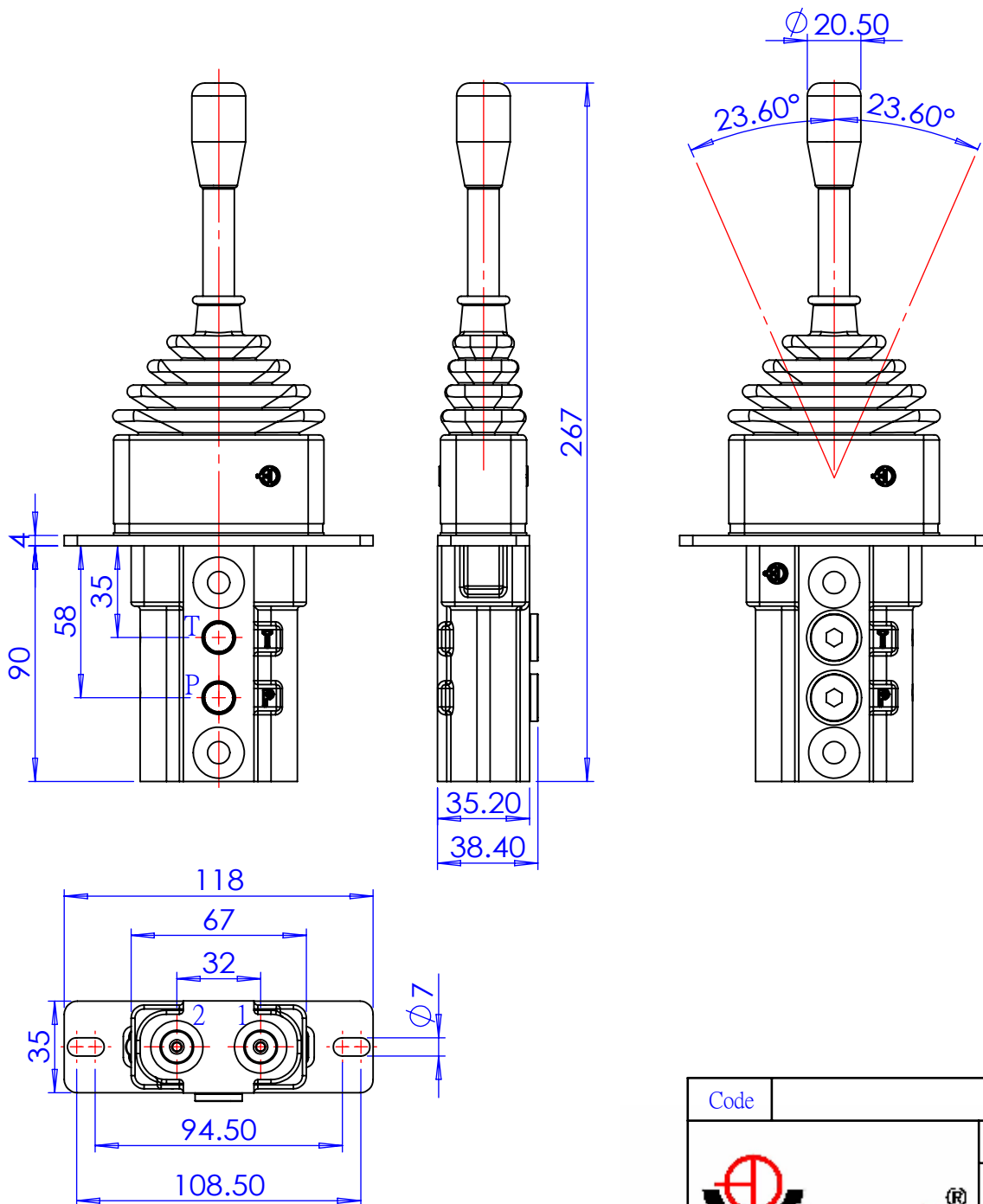

Standard threads

PORTS	BSP	UN-UNF	METRIC
Inlet P	G 1/4	7/16 - 20 (SAE 4)	M12x1.5
A and B ports	G 1/4	7/16 - 20 (SAE 4)	M12x1.5
Outlet T and power beyond C	G 1/4	7/16 - 20 (SAE 4)	M12x1.5

Flow	5~20 L/min	1.3~5.3 US gpm
Feeding pressure	30~100 bar	435~1450 psi
MAX. backpressure	3 bar	4.35 psi
Internal leakage at 30 bar/435 psi	10 ~ 18 cm ³ /min	0.61~1.1 in ³ /min
Fluid	mineral oil	
Fluid temperature	-10 ~ 80°C	-14 ~ 176°F
Ambient temperature	-40 ~ 60°C	-40 ~ 140°F

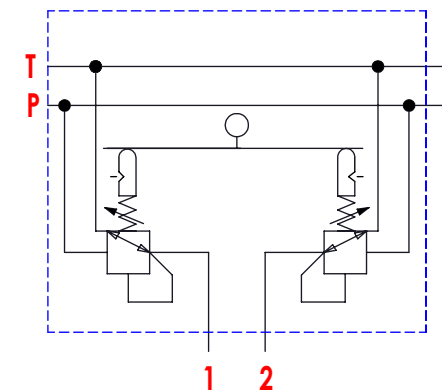

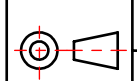
Code							
	Designer	蔡宗原	Date	2013/02/20	Valve type	JHP1	
	Drawer	蔡宗原	Date	2014/03/19	Description	1S-9-1	
油力油壓工業股份有限公司 YOULI HYDRAULIC INDUSTRIAL CO., LTD.						Unit	mm
						Scale	1:2.5

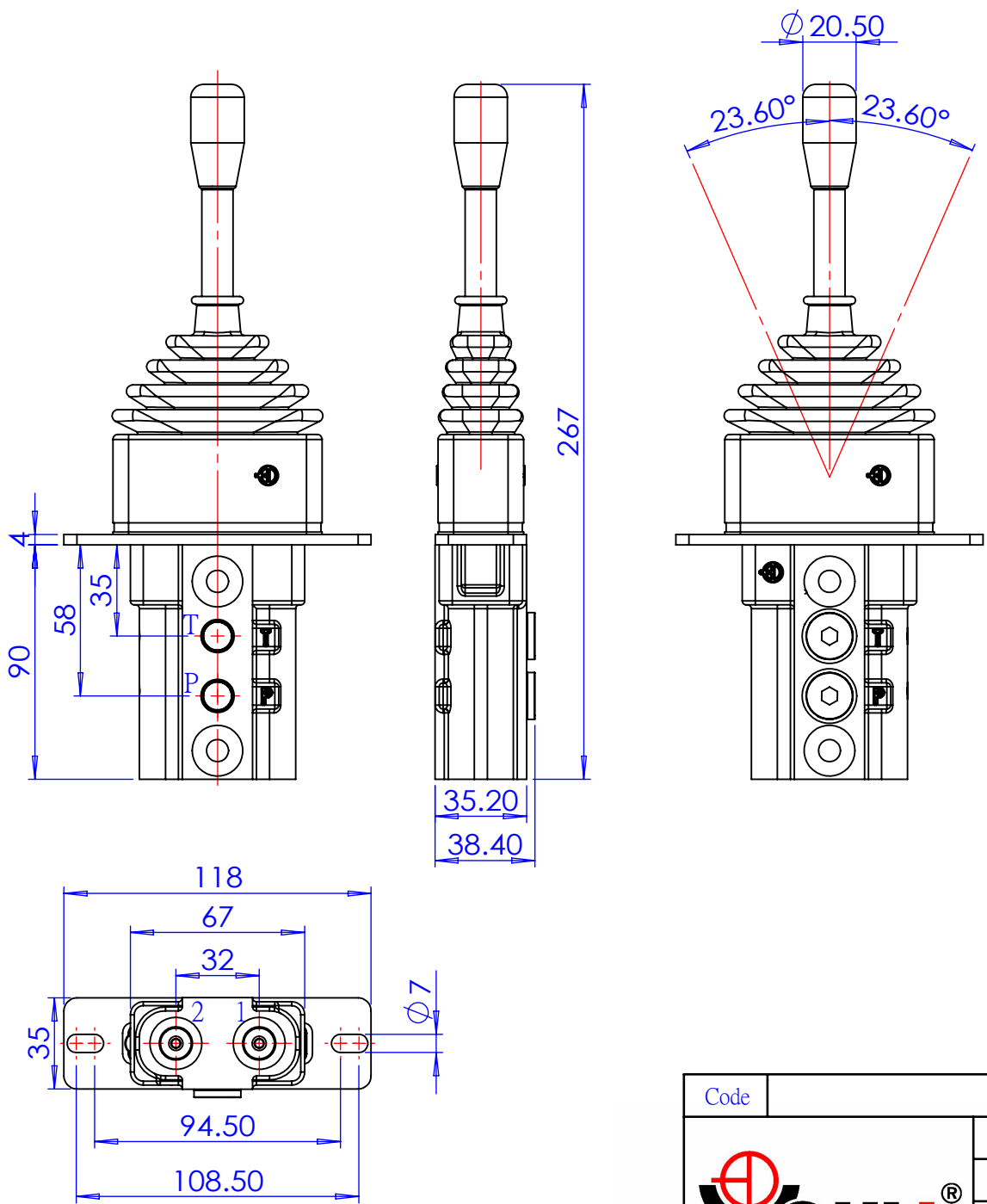

Standard threads

PORTS	BSP	UN-UNF	METRIC
Inlet P	G 1/4	7/16 - 20 (SAE 4)	M12x1.5
A and B ports	G 1/4	7/16 - 20 (SAE 4)	M12x1.5
Outlet T and power beyond C	G 1/4	7/16 - 20 (SAE 4)	M12x1.5

Flow	5~20 L/min	1.3~5.3 US gpm
Feeding pressure	30~100 bar	435~1450 psi
MAX. backpressure	3 bar	4.35 psi
Internal leakage at 30 bar/435 psi	10 ~ 18 cm ³ /min	0.61~1.1 in ³ /min
Fluid	mineral oil	
Fluid temperature	-10 ~ 80°C	-14 ~ 176°F
Ambient temperature	-40 ~ 60°C	-40 ~ 140°F

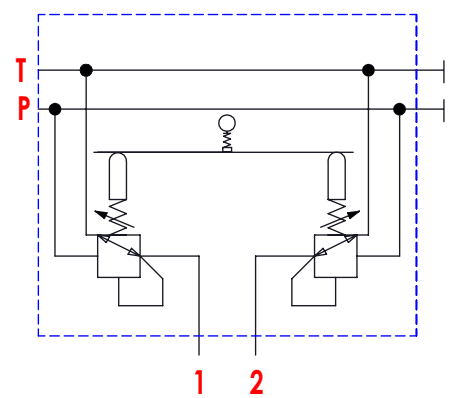

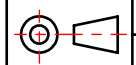
Code							
	Designer	蔡宗原	Date	2013/02/20	Valve type	JHP1	
	Drawer	蔡宗原	Date	2013/07/23	Description	1S-FD	
油力油壓工業股份有限公司 YOULI HYDRAULIC INDUSTRIAL CO., LTD.						Unit	mm
						Scale	1:2.5

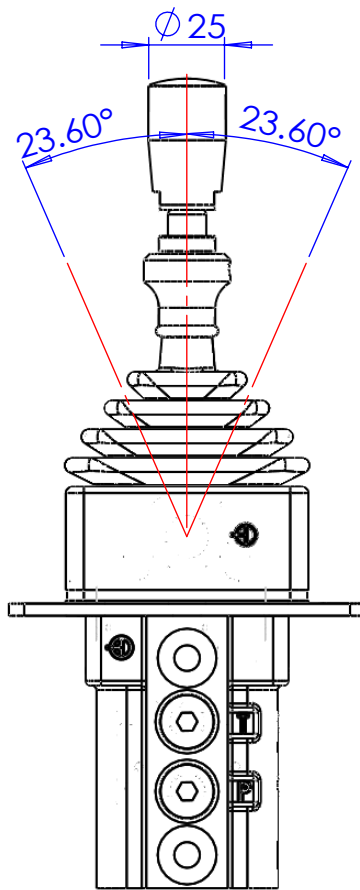
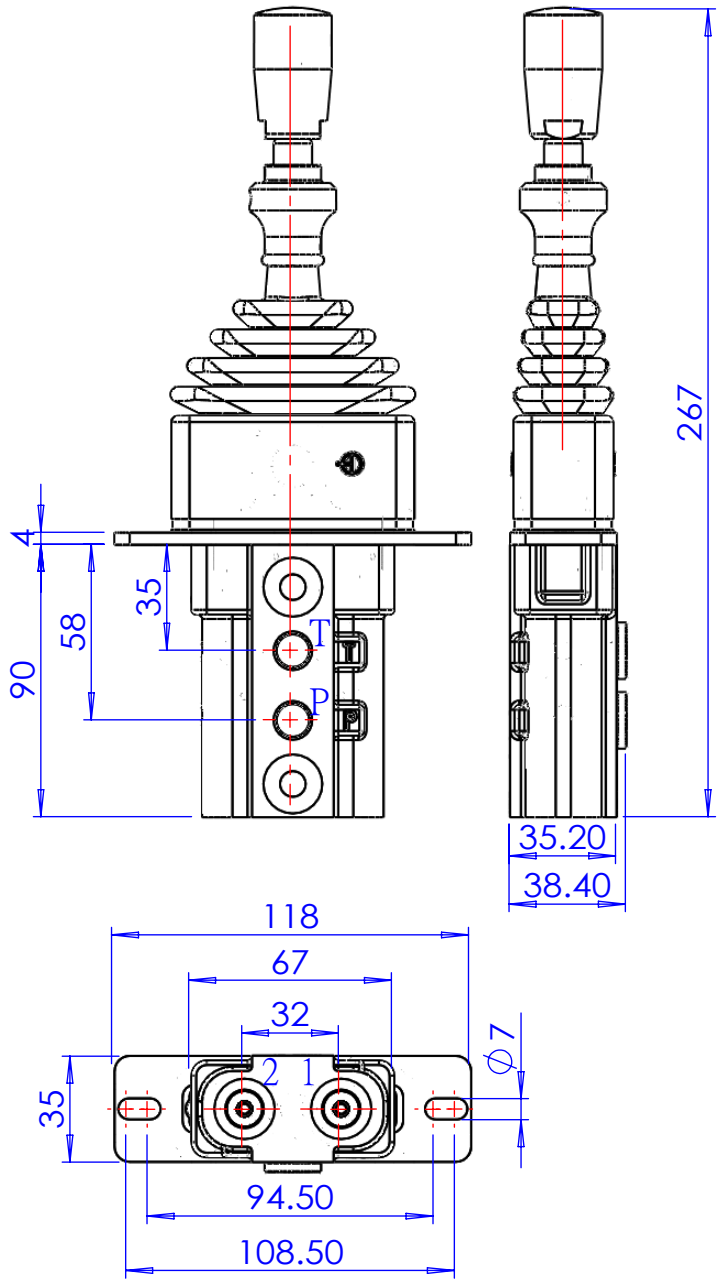

Standard threads

PORTS	BSP	UN-UNF	METRIC
Inlet P	G 1/4	7/16 - 20 (SAE 4)	M12x1.5
A and B ports	G 1/4	7/16 - 20 (SAE 4)	M12x1.5
Outlet T and power beyond C	G 1/4	7/16 - 20 (SAE 4)	M12x1.5

Flow	5~20 L/min	1.3~5.3 US gpm
Feeding pressure	30~100 bar	435~1450 psi
MAX. backpressure	3 bar	4.35 psi
Internal leakage at 30 bar/435 psi	10 ~ 18 cm ³ /min	0.61~1.1 in ³ /min
Fluid	mineral oil	
Fluid temperature	-10 ~ 80°C	-14 ~ 176°F
Ambient temperature	-40 ~ 60°C	-40 ~ 140°F

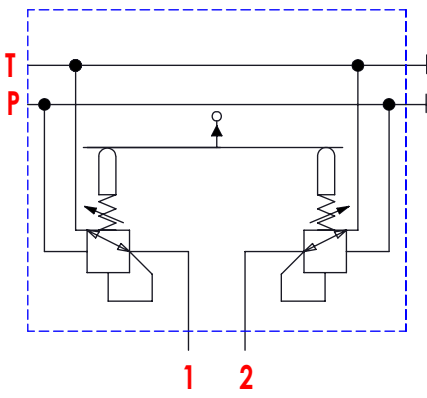

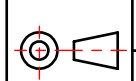
Code						
	Designer	蔡宗原	Date	2013/02/20	Valve type	JHP1
	Drawer	蔡宗原	Date	2013/08/08	Description	1S-LES
油力油壓工業股份有限公司 YOULI HYDRAULIC INDUSTRIAL CO., LTD.						Unit mm
						Scale 1:2.5