

壓力控制閥 (減壓閥附止回閥)

PRESSURE CONTROL VALVE (Pressure reducing valve with check valve)

- RCT 系列單向減壓閥是屬於支回路元件，其功能有二：
 - (1) 用於設定低於主回路之壓力。
 - (2) 可利用遠程控制口，作遠程控制用途。
- One-way pressure reducing with check valve is used branch circuit there are two functions below:
 - (1) Using to set the pressure below of the main hydraulic circuit.
 - (2) By using the remote control port for operation of remote control.



RCT-03. 06. 10

型號意義 How to order :

R C T - 06 - ※

1 2 3 4 5

1	系列號	Series
2	附止回閥	With check valve
3	管式連接	Threaded connection
4	口徑代號	Valve size 03:3/8", 06:3/4"
5	壓力調整範圍	Pressure adjusting range

產品規格 Specification :

名稱 Name	口徑 Valve Size	型號 Model	壓力調整範圍 Pessure Adj. Range (Kgf/cm ²)	最大流量 Max. Flow (ℓ/min)	重量 Weight (Kg)
減壓閥附止回閥 Reducing pressure with check valve	3/8	RCT-03	B: 7~70	50	4.5
	3/4	RCT-06	C: 35~140	125	7.8
	1-1/4	RCT-10	H: 70~210	250	13.8

圖形符號 Graphic symbol :

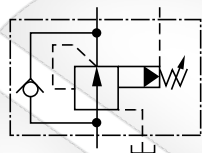

RCT

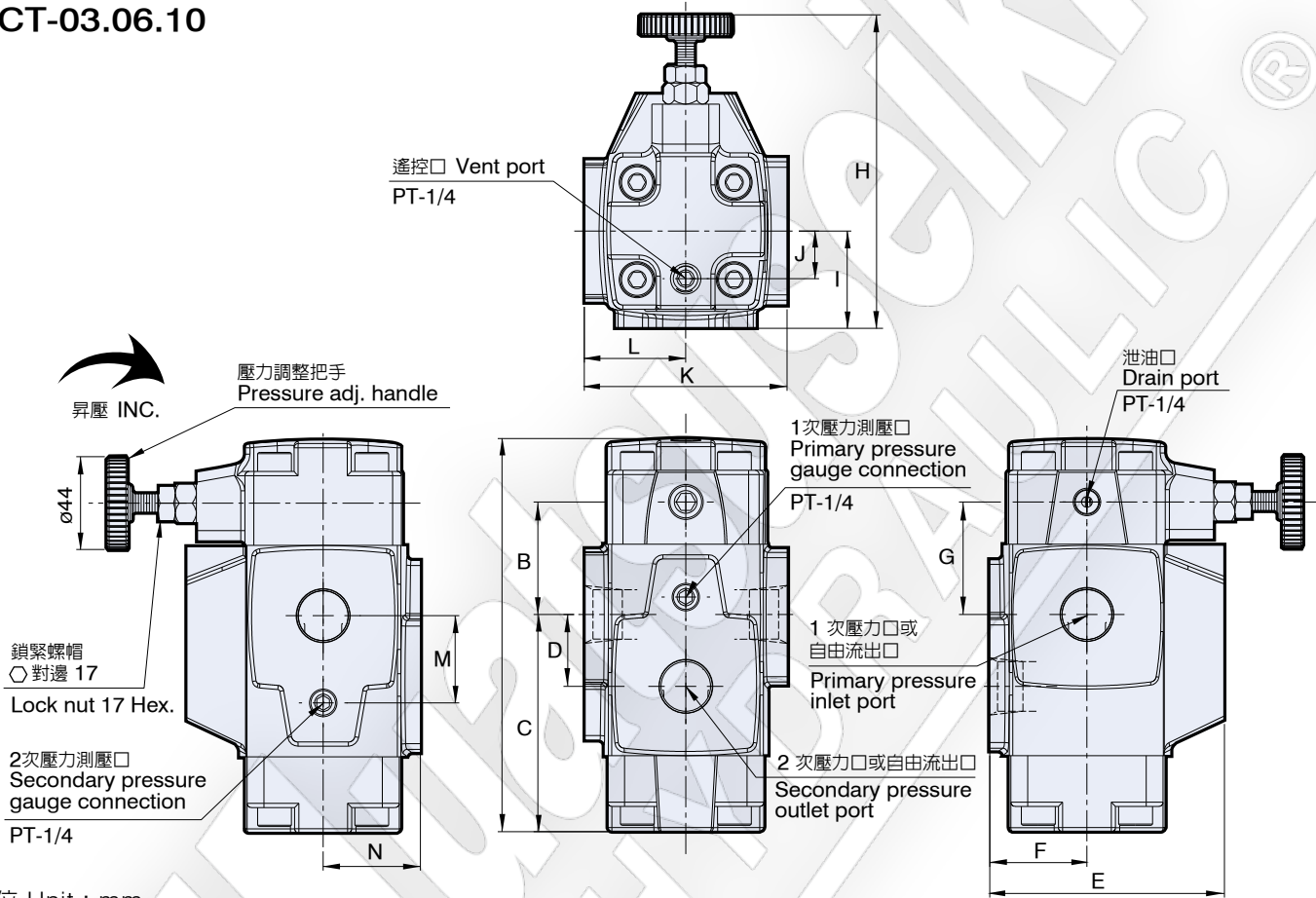
RCT-03.06.10

單位 Unit : mm

型號 Model	A	B	C	D	E	F	G	H	I	J	K	L	M	N
RCT-03	159	48	87.5	30	95	41.5	47	148.7	41.5	14.75	80	40	30	41.5
RCT-06	181	54.5	97	34	111	46	54.5	148.1	46	22.5	96	48	42	46
RCT-10	221	67	193	40	154	64	67	166	64	30	133	66.5	53	64

性能曲線圖 Performance curves

■ 流量-壓力特性曲線圖

The characteristic curve chart of Flow vs. Pressure

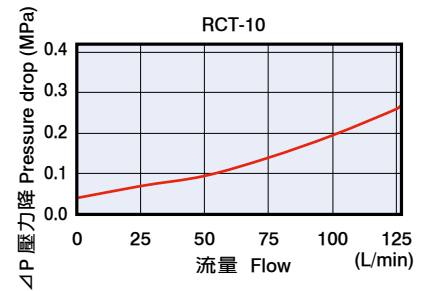
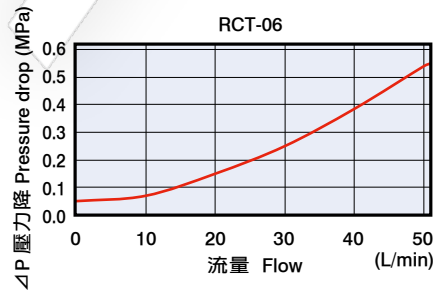
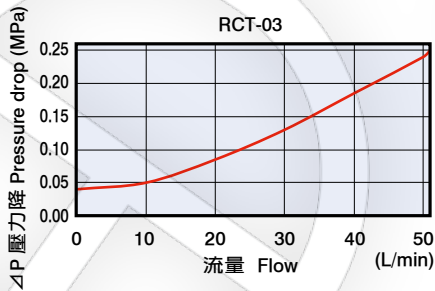
 使用油：黏度 Test fluid viscosity: 35mm²/s{cSt}
 比重 Specific gravity of 0.850

■ 粘度係數表 Viscosity

粘度	mm ² /s{cSt}	15	20	30	40	50	60	70	80	90	100
Viscosity	SSU	77	98	141	186	232	278	324	371	471	464
係數 Coefficient		0.81	0.87	0.96	1.03	1.09	1.14	1.19	1.23	1.27	1.30

爆炸圖 How to order for a complete assembled valve

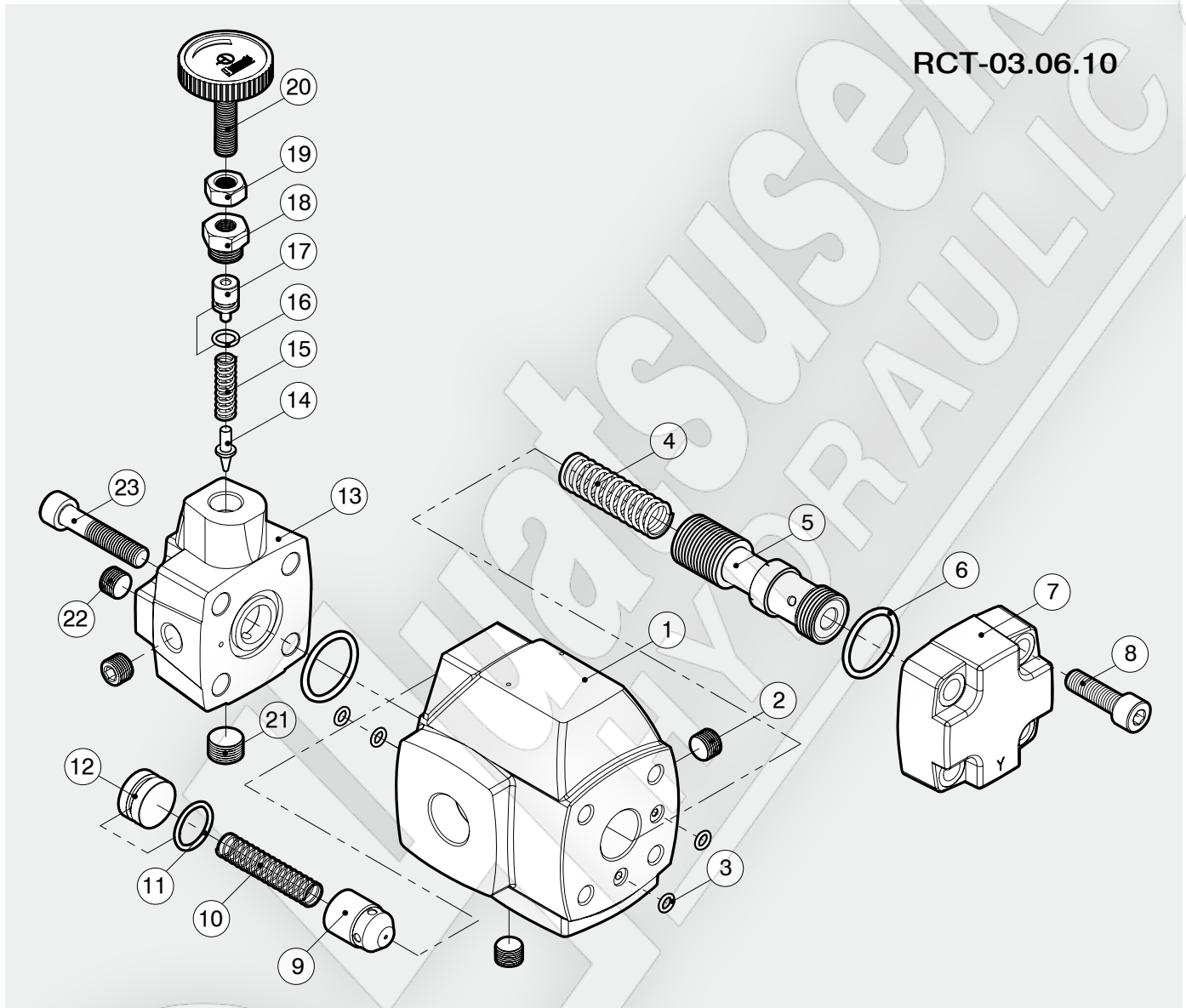

項次編號 No.	品名 Name of parts	數量 Q
1	本體 Body	1
2	PT 1/4	2
3	RCT-03.06 JIS B 2401-1B-P6	4
	RCT-10 JIS B 2401-1B-P9	4
4	彈簧 Spring	1
5	心軸 Spool	1
6	RCT-03 JIS B 2401-1B-G25	2
	RCT-06 JIS B 2401-1B-G30	2
	RCT-10 JIS B 2401-1B-P34	2
7	閥蓋 Cover	1
	RCT-03 M8 x 35L	4
8	RCT-06 M10 x 35L	4
	RCT-10 M12 x 40L	4
9	槍子閥 Check valve	1
10	止回閥彈簧 Spring	1
11	RCT-03 JIS B 2401-1A-P12	1

項次編號 No.	品名 Name of parts	數量 Q
11	RCT-06 JIS B 2401-1A-P20	1
	RCT-10 JIS B 2401-1A-P20	1
12	推桿 Push rod	1
13	壓力調整閥蓋 Cover	1
14	針閥 Pilot poppet	1
15	彈簧 Spring	1
16	JIS B 2401-1A-P9	1
17	推桿 Push rod	1
18	把手螺母 Nut	1
19	六角螺母 Nut	1
20	壓力調整把手 Pressure adj. handle	1
21	PT 3/8	1
22	PT 1/4	2
	RCT-03 M8 x 45L	4
23	RCT-06 M10 x 50L	4
	RCT-10 M12 x 45L	4